

USER MANUAL

OEM PCB - Amplification and Anticipation for UD Disks
For PCB Version D, E, F, G and H

WARRANTY

The Gentec-EO OEM PCB carries a one-year warranty (from date of shipment) against material and/or workmanship defects, when used under normal operating conditions. The warranty does not cover damages related to misuse.

Gentec-EO Inc. will repair or replace, optionally, any OEM PCB that proves to be defective during the warranty period, except in the case of product misuse.

Any attempt by an unauthorized person to alter or repair the product voids the warranty.

The manufacturer is not liable for consequential damages of any kind.

In case of malfunction, contact your local Gentec-EO distributor or nearest Gentec-EO Inc. office to obtain a return authorization number. The material should be returned to:

Gentec Electro-Optics, Inc.
445, St-Jean-Baptiste, Suite 160
Québec, QC
Canada G2E 5N7
Tel: (418) 651-8003
Fax: (418) 651-1174
e-mail: info@gentec-eo.com
website: www.gentec-eo.com

CLAIMS

To obtain warranty service, contact your nearest Gentec-EO agent or send the product, with a description of the problem, transportation and insurance prepaid, to the nearest Gentec-EO agent. Gentec-EO Inc. assumes no risk for the damage in transit. Gentec-EO Inc. will, at its option, repair or replace the defective product free of charge or refund your purchase price. However, if Gentec-EO Inc. determines that the failure is caused by misuse, alterations, accident or abnormal condition of operation or handling, it would therefore not be covered by the warranty.

SAFETY INFORMATION

Do not use the OEM PCB if the device or the detector looks damaged, or if you suspect that the OEM PCB is not operating properly.

Caution: Changes or modifications not expressly approved in writing by Gentec-EO Inc. may void the user's authority to operate this equipment.

SYMBOLS

The following international symbols are used in this manual:



Refer to the manual for specific Warning or Caution information to avoid any damage to the product.



DC, Direct Current

TABLE OF CONTENTS.

1. THE OEM PCB.

1.1	INTRODUCTION.....	3
1.2	SPECIFICATIONS	3
1.3	POWER SUPPLY	4
1.4	CONNECTING THE DISK TO THE PCB.	4
1.5	AVOIDING NOISE.....	4
1.6	REMOVING THE ANTICIPATION.....	4
1.7	ADJUSTING THE OEM PCB.	5
1.8	APPENDIX 1	6

LIST OF ILLUSTRATIONS

FIG 1-1	THE OEM PCB POTENTIOMETER.	5
FIG 1-2	VIEW OF THE OEM PCB IC SIDE	6
FIG 1-3	VIEW OF THE OEM PCB POTENTIOMETER SIDE.	7
FIG 1-4	THE OEM PCB	8

1 THE OEM PCB

1 ▼ Introduction

The OEM PCB contains 1 amplification circuit and 1 anticipation circuit. The circuits are wired in series. The OEM PCB requires only 1 single power supply. The negative power is generated on board. The OEM PCB gain is factory adjusted, but there is a potentiometer for fine tuning. The anticipation potentiometer is set at mid range and may have to be tune with the OEM head. There is also a potentiometer to adjust the offset of the amplification circuit.

1.1 Specifications

The following specifications are based on a one-year calibration cycle, an operating temperature of 18 to 85°C (64 to 185°F) and a relative humidity not exceeding 80%.

Table 1-1 List of Specifications

OEM PCB specifications	
Input range	-0.7 to VDD-3V
Output Voltage	-0.3 to VDD-3 Volts to a maximum of 12 V.
Response Time (accelerated)¹	Head dependant
Maximum temperature	85 °C
No load current consumption	8 mA
Output Impedance	50 ohms
Input Impedance	>10 Mohms
Dimensions	41 (L) x 29 (W) x 18 max (H) mm
Weight	10 g
Output and power Connector type	4 pins Male Molex: part number 22-27-2041 4 pins Female Molex: part number: 22-01-2045 Terminal part number: 08-50-0032
Disc connector	3 pins Male Molex: part number 22-27-2031 3 pins Female Molex: part number 22-01-2035 Terminal part number: 08-50-0032
Connector hole size	38 mils
Connector hole spacing	100 mils
<u>External Power Supply</u>	
Power supply range (VDD)	12 to 16 VDC

1.2 Power Supply

The OEM PCB needs only a positive power supply, the negative power supply is generated on-board. The OEM PCB is protected against voltage inversion and voltage spikes. The internal voltage is limited via a 15 V zener diode. The maximum supply is 16 V. Do not connect the Output to the Power, it will damage the PCB.

The maximum output voltage is limited by the voltage drop of the analog circuit. The output formula is -0.3 to $VDD-3$ Volts to a maximum of 12 V. Here is a table for quick reference.

Power supply voltage (VDD)	Maximum Output
16 V	12 V
14 V	11 V
13 V	10 V
12 V	9 V

1.3 Connecting the disk to the PCB.

We recommended the distance between the disc and PCB to be as short as possible. When the OEM disk is less than 3 inch apart from the PCB, use two gage 26 wires. Connect the disk using the molex 3 pin connector. If the disk is far from the PCB, it is recommended to use a shielded two wire cable, ex: Belden # "9397 black". The output of the OEM PCB will not work in the negative input voltage. The output pad is P4 or pin 1 of J1. The cable length between the PCB and the measuring device should be less than 2 meters.

1.4 Avoiding Noise

The OEM PCB may have a high gain configuration, making it very sensitive to external noise. It is recommended to shield the OEM PCB in a metal box. It is also recommended to connect the GND to all parts touching the disk. If you still have noise, you will have to shield the disk, wires and PCB.

1.5 Removing the Anticipation

If the OEM PCB is in a noisy environment, the anticipation circuit can sometimes cause additional noise in the measure. To remove the anticipation remove Resistor R22 see Fig # 1-3. You will need to adjust the offset. See section 1.7. The gain will not change.

1.6 Adjusting the OEM PCB.

The OEM PCB has 3 potentiometers:

Potentiometer R7 is the offset adjustment.

Potentiometer R5 is the gain adjustment.

Potentiometer R6 is the anticipation adjustment.

The gain is factory adjusted, but the potentiometer has a $\pm 30\%$ adjustment. The anticipation is factory adjusted, but the anticipation potentiometer has a $\pm 30\%$ adjustment.

Procedure:

Connect the disk using the 3 pin female connector. The center pin is not used.

Insert the Output/power 4 pin female Molex connector.

Plug the power supply.

Plug the output to a voltmeter.

Wait until the sensor is thermally stabilized. Adjust to zero the offset with R7.

Turn on the light source. If necessary, adjust the Gain using R5.

To adjust the anticipation, plug the output to an oscilloscope.

Step 1: Turn on the light source,

Step 2 : Look at the shape of the output signal. If the signal is too slow, turn R6 counterClockwise. If the signal is too fast turn R6 clockwise.

Step 3: Go to step 1

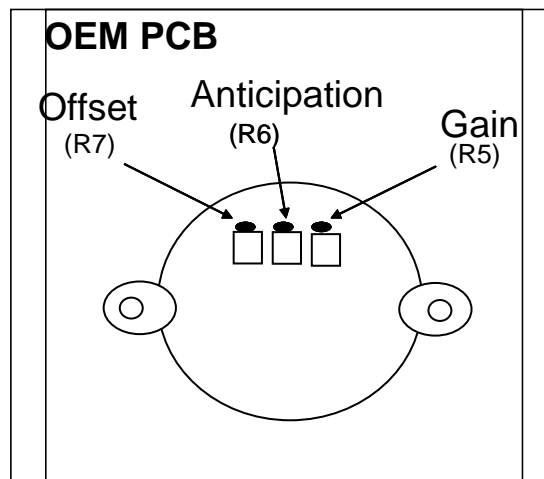

Fig 1-1 The OEM PCB Potentiometer.

1.7 Appendix 1

Before making your cable, make sure you check the pin out of J1 because the viewing direction change the order of it.

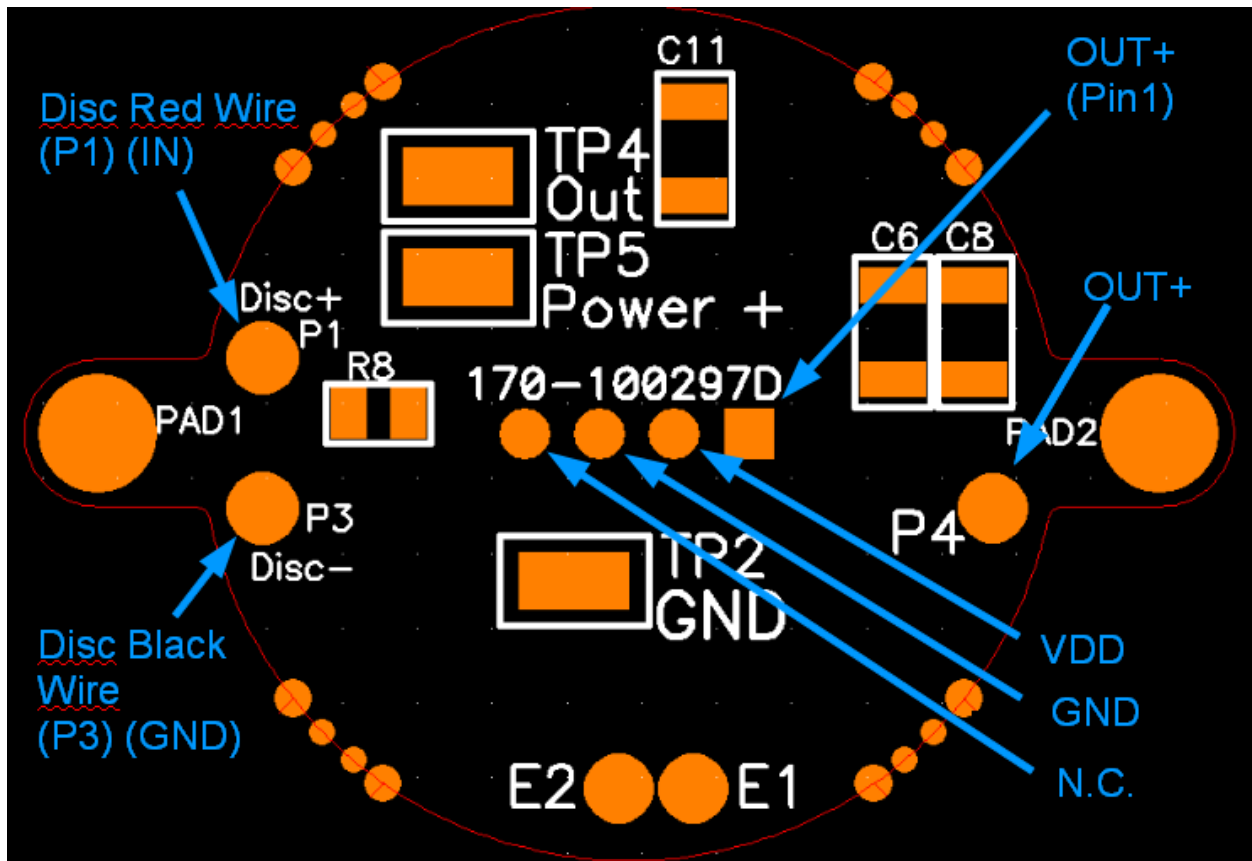

Fig 1-2 View of the OEM PCB IC side

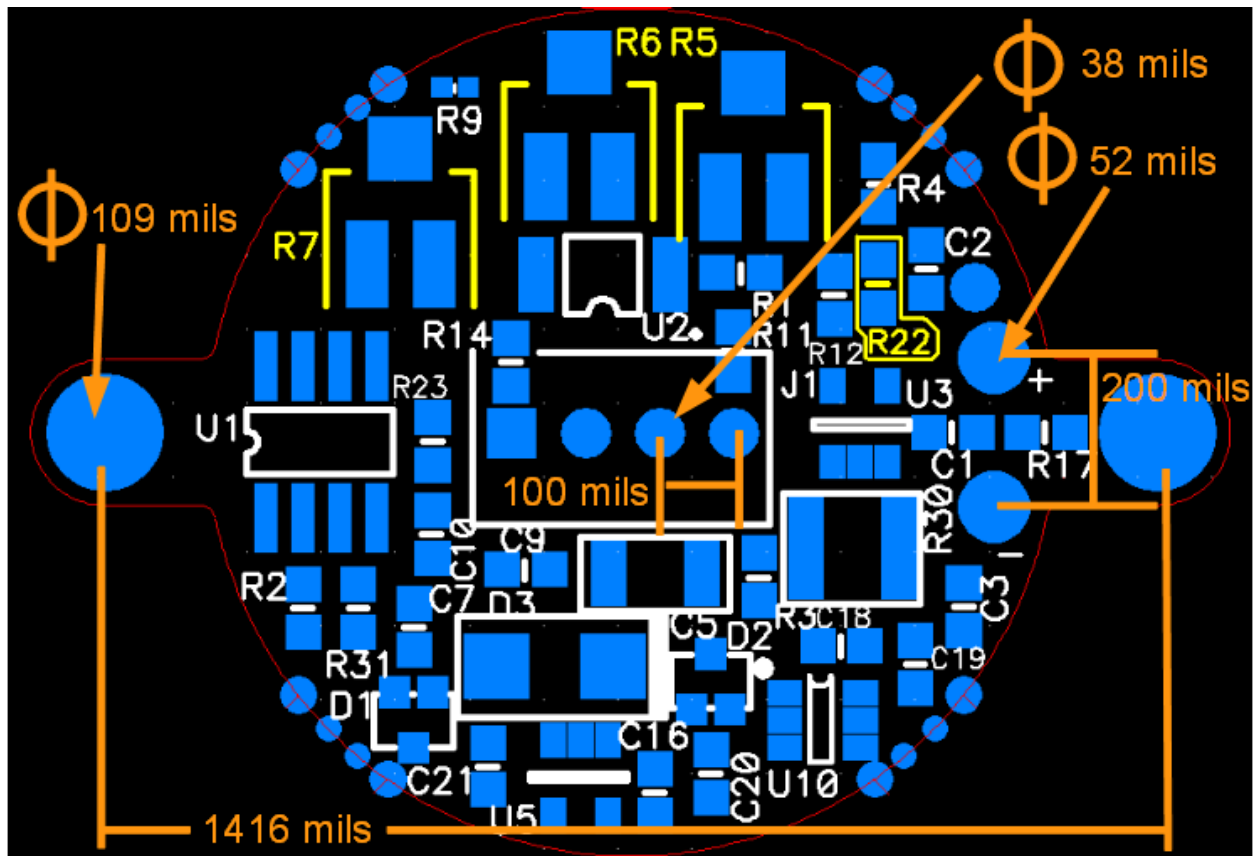

Fig 1-3 View of the OEM PCB potentiometer side.

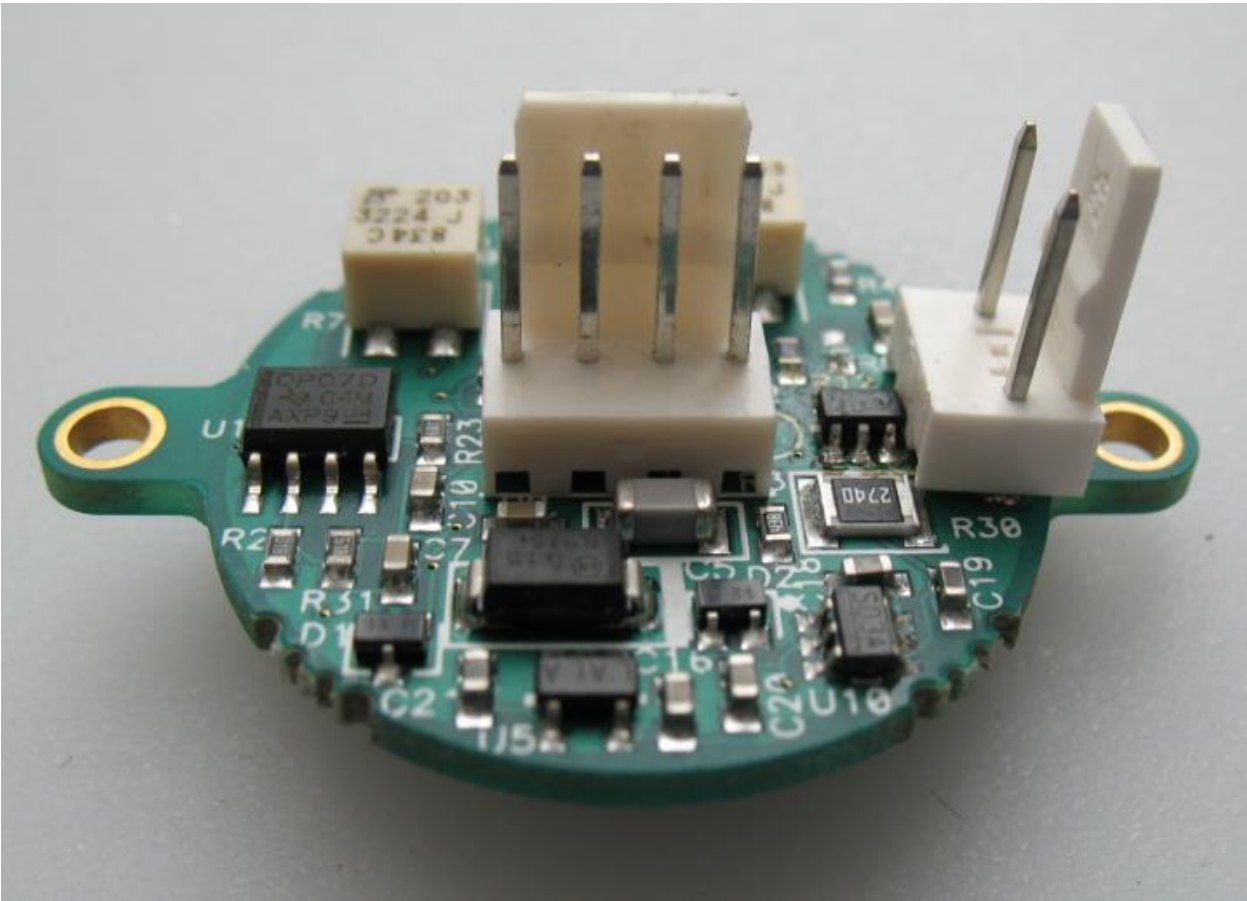

Fig 1-4 The OEM PCB



LEADER IN LASER BEAM MEASUREMENT SINCE 1972

POWER & ENERGY METERS



BEAM PROFILING



TERAHERTZ MEASUREMENT



CANADA

445 St-Jean-Baptiste, Suite 160
Quebec, QC, G2E 5N7, Canada
T (418) 651-8003
F (418) 651-1174
1 (888) 5GENTEC (Canada and USA only)
info@gentec-eo.com

UNITED STATES

5825 Jean Road Center
Lake Oswego, OR, 97035, USA
T (503) 697-1870
F (503) 697-0633
1 (888) 5GENTEC (Canada and USA only)
info@gentec-eo.com

CALIBRATION CENTERS

445 St-Jean-Baptiste, Suite 160
Quebec, QC, G2E 5N7, Canada
Werner von Siemens Str. 15
82140 Olching, Germany
1-11-14, Kasuga, Bunkyo-ku,
Tokyo 112-0003, Japan